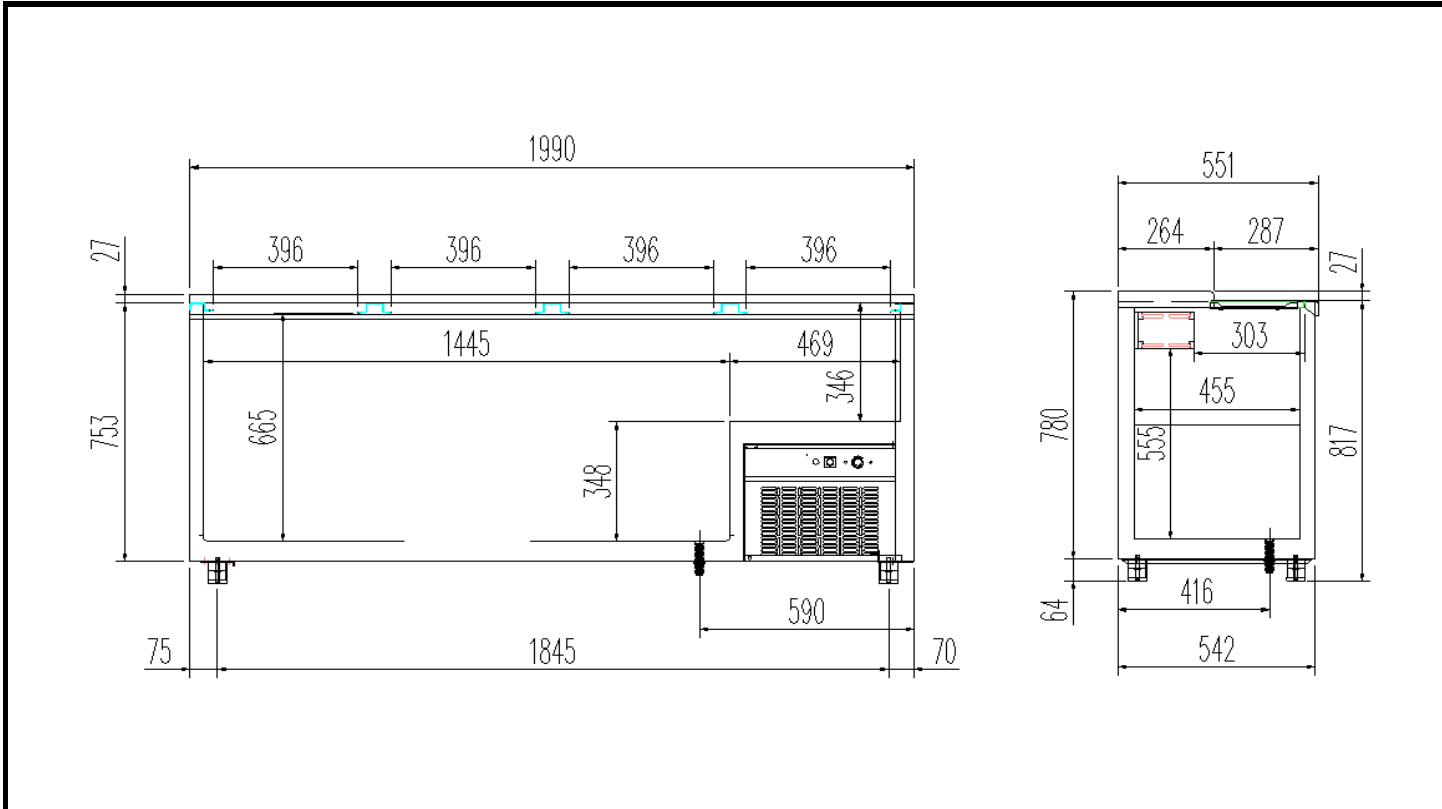

IMAGE / DETAIL



TECHNICAL DRAWING



Every photo should be considered as a reference



Ctra. Córdoba - Málaga Km. 75.800
 Tlfs: +34957 510126 Fax: +34957510682
 14900 LUCENA (Córdoba), Spain
info@docriluc.es
www.docriluc.com

MODEL:	EBI-200	FAMILY:	MERCHANDISER	MANUFACTURER:	
---------------	---------	----------------	--------------	----------------------	---

ELECTRICAL DATA

REFRIGERANT	Type	R-600a Isobutane
EVAPORATOR	Type	COOPER TUBE AND ALUMINIUM FINS
CONDENSER	Type	COOPER TUBE AND ALUMINIUM FINS
CONTROLLER	Type / Model	MECHANICAL
BLOWING AGENT	Type	C4H5F5
INSULATION	Type (Density kg/m ³)	Polyurethane (40)

CLIMATIC CLASS	Nº (°C / % H.R.)	3 (25°C 60% H.R.)
STANDARD LIGHTING POWER	Type / Position (W)	-
PRODUCT TEMPERATURE	Type (°C)	2+8°C
RANGE WORKING TEMPERATURE	°C	2+8°C

GENERAL DATA

EXTERNAL DIMENSIONS	WxDxH mm	1990x550x850
INTERNAL DIMENSIONS	WxDxH mm	1914x455x555
GROSS VOLUME	l	580
INNER DIVIDER	Number (WxD mm)	3
TDA	m ²	NA
33cl CANS CAPACITY	Number	-
33cl CANS FACINGS	Number	-

PACKAGING DIMENSIONS	WxDxH mm	2020x570x955
DELIVERY BATCH	Type (number)	Palletized box (1units)
NET WEIGHT	Kg	96
COOLING CAPACITY	W	304
NOMINAL POWER	W	180

TECHNICAL FEATURES

EXTERIOR MATERIAL	Type	STAINLESS STEEL AISI304 18/10
INTERIOR MATERIAL	Type	STAINLESS STEEL AISI304 18/10
DOOR /CURTAIN	Type	STAINLESS STEEL AISI304 18/10
EXTRA INFORMATION		-
SILKSCREEN / PRINTING	Drawing	-

QUALITY REQUIREMENTS

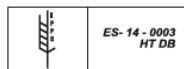

Every photo should be considered as a reference

Ctra. Córdoba - Málaga Km. 75.800
 Tlfs: +34957 510126 Fax: +34 957510682
 14900 LUCENA(Córdoba), Spain
info@docriluc.es
www.docriluc.com